

Electronic Cruise Control for Honda VFR800FI to 2001



Note: Before ordering this cruise control, check the electrical plugs on the rear brake light switch. Earlier models (up to 2000) use two bullet connectors, later models (2001 on) use a three way plug.

The following provides a brief description of the power consumption and component locations of the MotorCycle Setup electronic cruise control.

Current draw while the cruise is switched on, but not engaged, is approximately 0.020 amp (0.28 watts). Current draw while the cruise is engaged is nominally 0.250~0.350 amp (3.5~5 Watts) with peak draw at 0.5 amp (7 Watts).

By comparison, a head light bulb typically draws about 4 amps (55 Watts), and a tail light bulb (running light) draws about 0.4 amp (5 Watts).

Installed weight of the cruise control is approximately 1.4kg.

The **Computer (1)** mounts on the right hand side of the seat support rails under the rear fairing cowl. It can be seen here at the top left of the photo.



The **Actuator (2)** is bolted to the front of the motor beside the oil filter, using one of the starter motor mounting bolts and a lug on the oil pan. A **vacuum hose assembly (4)** is provided to connect the actuator to the engine.



The actuator cable acts on a **lever assembly (3)** that bolts on the end of the injection throttle spindle.



The **Switch (5)** is mounted to the left hand (clutch) master cylinder handlebar clamp. The bracket mounts between the bottom faces of the clamp. The clamp must have about 1~1.5mm (0.040"~0.060") filed from the bottom face to allow for the thickness of the switch bracket.

The **Wiring Loom (6)** uses the same type of plugs that are already used on the motorcycle. Brake sensing is taken off the brake light switches by unplugging the rear brake light switch. Matching connectors on the cruise control loom are plugged in to the switch and the bikes loom. Power is also taken from the brake light circuit. Earth (ground) is taken from a bolt on the frame. Speed sensing is taken off the bikes electronic speedometer. The sender unit is unplugged from the loom and the matching connectors on the cruise control loom are plugged into the sender unit and the bikes loom.

The **Electronic Clutch Switch (ECS)** is now standard on this kit and is connected to the bikes ignition system. If the rider inadvertently disengages the clutch it will cancel the cruise control. It mounts on the rear frame or rear mudguard (fender) near the cruise computer.

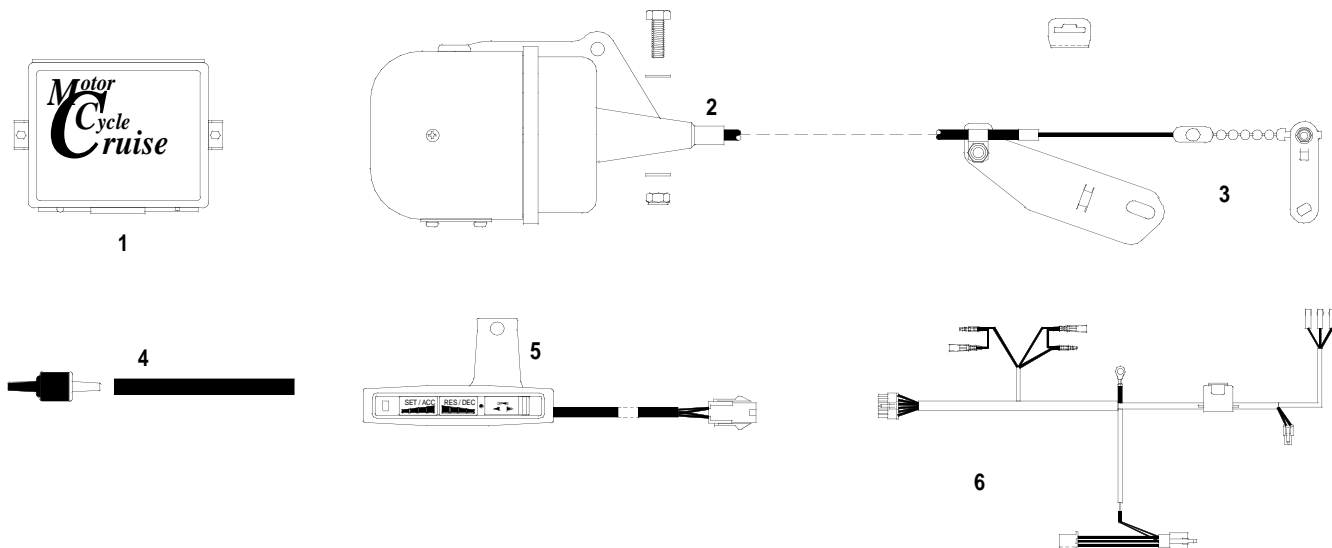

Available for delivery worldwide: [email info@quadcruise.co.uk](mailto:info@quadcruise.co.uk)

O.W.L. Vehicle Electronic Systems Ltd
 O.W.L. House PO Box 1330
 TAMWORTH B77 1AG
 UK
 tel 01827 60577 fax 01827 60579
www.motorcyclecruise.co.uk



2003/346