

Electronic Cruise Control for Honda Transalp XL650V



The following provides a brief description of the power consumption and component locations of the MotorCycle electronic cruise control.

Installed weight of the cruise control is approximately 2.5kg.

Current draw while the cruise is switched on, but not engaged, is approximately 0.250 amp (3 watts). Current draw while the cruise is engaged is nominally 0.50~0.80 amp (6~10 Watts). By comparison, a head light bulb typically draws about 4 amps (55 Watts), and a tail light bulb (running light) draws about 0.4 amp (5 Watts).

Refer to the line drawing on the back of this sheet to identify the component numbers in the text.

The **Computer (1)** mounts in front of the tail light under the seat. It is mounted in a **foam block (2)**



The **Actuator (3)** is bolted to the bottom of the storage compartment under the seat and sits in the left hand front corner of the compartment.

A 6.5mm (1/4") hole must be drilled in the bottom of the luggage compartment to mount the actuator, as well as holes for the vacuum hose and the actuator wiring.

A **vacuum hose assembly (4)** is provided to connect the actuator to the engine.



The **Cable Interface Unit (5)** is located on the left side of the engine.

A new **cable (6)** connects it to the carburetors



The **Speed Sensor (7)** is mounted on the right side of the swing arm, using one of the rear brake calliper mounting bolts.

Nickel plated magnets are placed in the heads of the bolts that mount the brake disc.

The **Control Switch (8)** is mounted on the left side mirror stalk, above the bike's switch gear.



The **Wiring Loom (9)** uses the same type of plugs that are already used on the motorcycle. Power for the cruise control and brake sensing is taken from the brake light switches by unplugging the rear brake light switch. Matching connectors on the cruise control loom are plugged in to the switch and the bike's loom. Tach (engine speed) sensing is detected from the bike's ignition coils. This is used to disengage the cruise control if the clutch is operated. The bike's clutch switch is also connected to the cruise control to disengage the cruise control. The cruise control is grounded on the negative battery terminal.

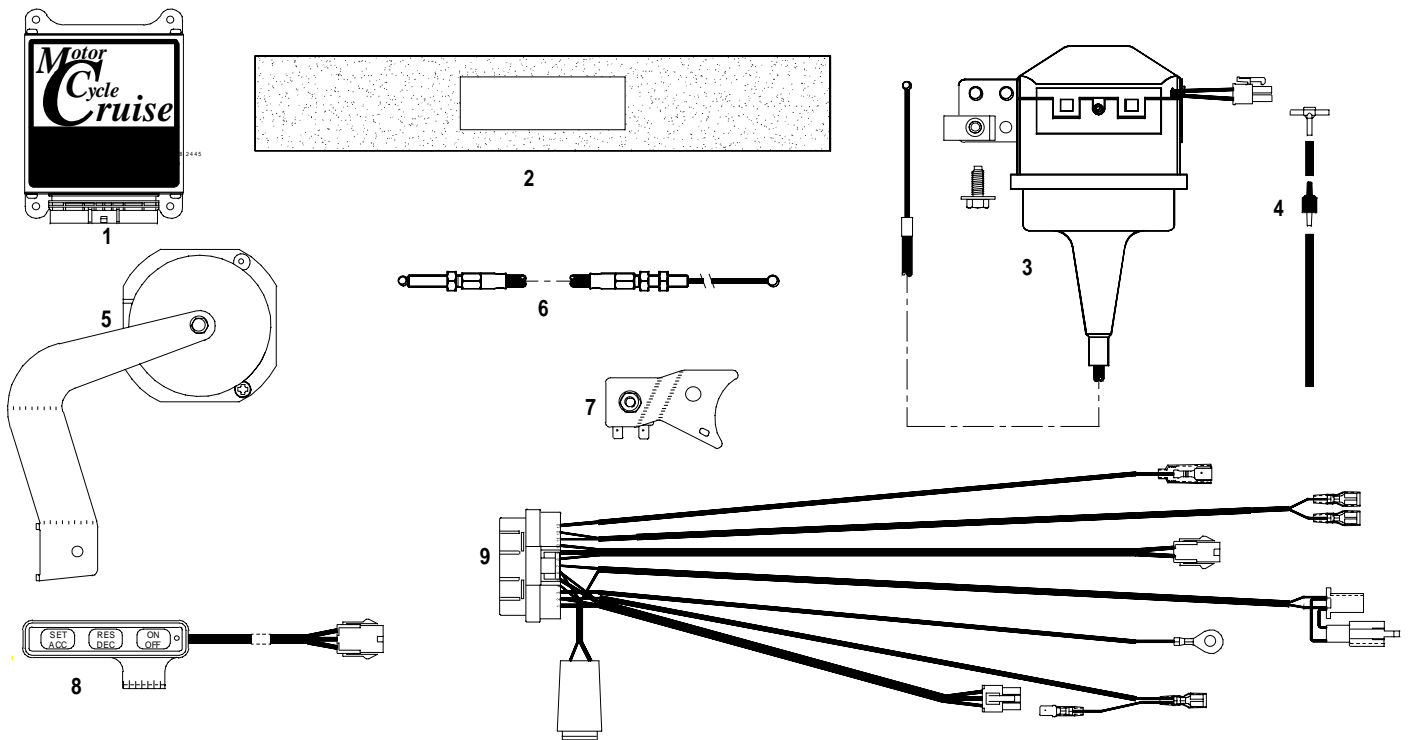

Available for delivery worldwide: www.motorcyclecruise.co.uk

O.W.L. Vehicle Electronic Systems Ltd
 O.W.L. House PO Box 1330
 TAMWORTH B77 1AG
 UK
 tel 01827 60577 fax 01827 60579



2003/346