

# Electronic Cruise Control for Honda GL1100 Gold Wing



The following provides a brief description of the power consumption and component locations of the MotorCycle Setup electronic cruise control.

Installed weight of the cruise control is approximately 1.5kg.

Current draw while the cruise is switched on, but not engaged, is approximately 0.020 amp (0.28 watts). Current draw while the cruise is engaged is nominally 0.250~0.350 amp (3.5~5 Watts) with peak draw at 0.5 amp (7 Watts).

By comparison, a head light bulb typically draws about 4 amps (55 Watts), and a tail light bulb (running light) draws about 0.4 amp (5 Watts).

Refer to the diagram on the back of the page to identify the components from the numbers in the text.

The **Computer (1)** mounts under the false fuel tank on the left side.



The **Actuator (2)** is located in the cavity just inside the left faring cooling air exhaust vent. A **vacuum hose assembly (3)** is provided to connect this to the engine. A threaded vacuum fitting replaces one of the carburettor balance port blanking screws.

The **CIU (4)** is mounted under the false fuel tank cover on the right side, behind the radiator coolant bottle and has a new **cable (5)** running from it to the carburetors.



The **Speed Sensor (6)** is on the left side of the rear swing arm mounted on the axle pinch bolt.. A new high tensile bolt is provided to replace the existing axle pinch bolt. The photo at right shows the speed sensor mounted on the motor cycle. A new **nut and magnet (7)** is provided to replace one of the rear disc brake mounting nuts.



The **Switch (8 a & b)** is mounted to the left hand (clutch) master cylinder handlebar clamp and is located under the left hand switch block. The bracket mounts on the clutch lever handlebar clamp bolt. There are two different brackets supplied in the kit to allow for different clutch lever assemblies on the bike. Photos of both types of mounting methods for the switch are shown at left and at right.



The **Wiring Loom (9)** uses the same type of plugs that are already used on the motorcycle. Brake sensing is taken off the brake light switches by unplugging the rear brake light switch. Matching connectors on the cruise control loom are then plugged in to the switch and the bike's loom. Power for the cruise is also taken from the brake light circuit. Earth (ground) is sourced on the earth bolt on the left side of the bike. An additional brake switch loom (9a) is provided to provide for older bikes that use different brake switch connections.

The **Electronic Clutch Switch (10)** is mounted under the false fuel tank near the cruise control computer on top of the bikes ignition module and is connected to the ignition coils. This device cancels the cruise in the event of the clutch being operated.

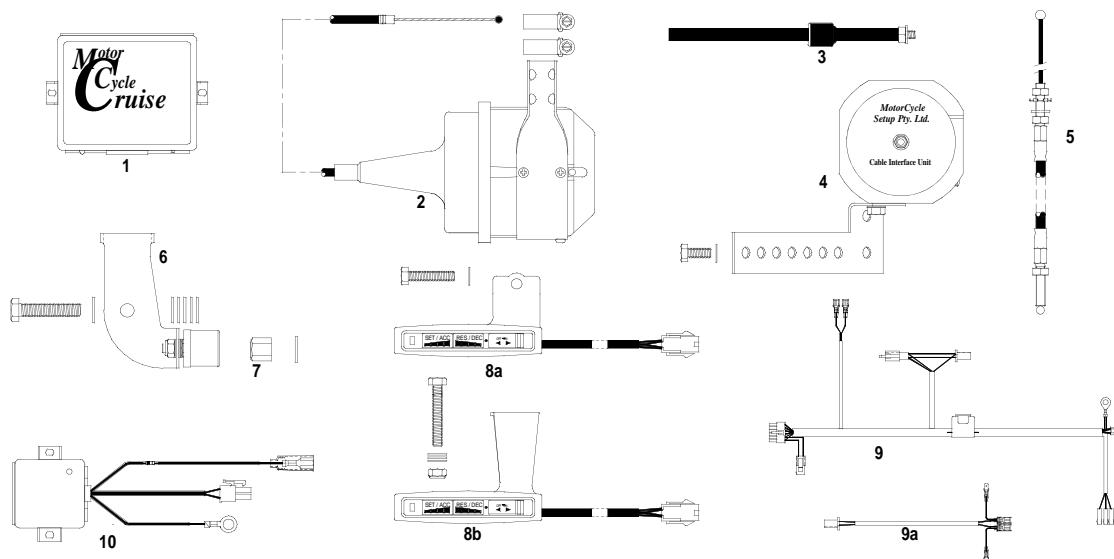

Available for delivery worldwide: [email info@quadcruise.co.uk](mailto:info@quadcruise.co.uk)

O.W.L. Vehicle Electronic Systems Ltd  
 O.W.L. House PO Box 1330  
 TAMWORTH B77 1AG  
 UK  
 tel 01827 60577 fax 01827 60579  
[www.motorcyclecruise.co.uk](http://www.motorcyclecruise.co.uk)



2003/346