

Electronic Cruise Control for **Harley Davidson** **FLSTC Softail & FLSTF Fat Boy**



Note: This cruise control is designed to fit Softails fitted with footboards and forward control heel and toe shift levers. It is not known if it will fit Softails fitted with normal toe shift levers at this time.

The following provides a brief description of the power consumption and component locations of the MotorCycle Setup electronic cruise control.

Current draw while the cruise is switched on, but not engaged, is approximately 0.020 amp (0.28 watts). Current draw while the cruise is engaged is nominally 0.250~0.350 amp (3.5~5 Watts) with peak draw at 0.5 amp (7 Watts).

By comparison, a head light bulb typically draws about 4 amps (55 Watts), and a tail light bulb (running light) draws about 0.4 amp (5 Watts).

Installed weight of the cruise control is approximately 2.1kg.

Refer to the line drawing on the back of this sheet to identify the component numbers in the text.

The **Computer (1)** mounts in the chrome horn cover on the left side of the motor. The horn is relocated to a new position under the voltage regulator and in front of the oil filter using a **bracket (2)** supplied in the kit. The photo shows the computer looking up from under the horn cover.



The **Actuator (3)** is mounted above and to the left side of the oil filter, near the gear shift lever. Aluminium covers are provided in black textured finish powder coat to provide protection from dirt and water and to enhance the appearance of the actuator. A **vacuum hose assembly (4)** is provided to connect the actuator to the engine.

The **CIU (5)** is under the fuel tank near the left front of the front cylinder head and has a new **cable (6)** running from it to the carburetors. The CIU is supplied with a polished stainless steel cover to enhance its appearance.

The photo shows the actuator and CIU mounted on the motorcycle.

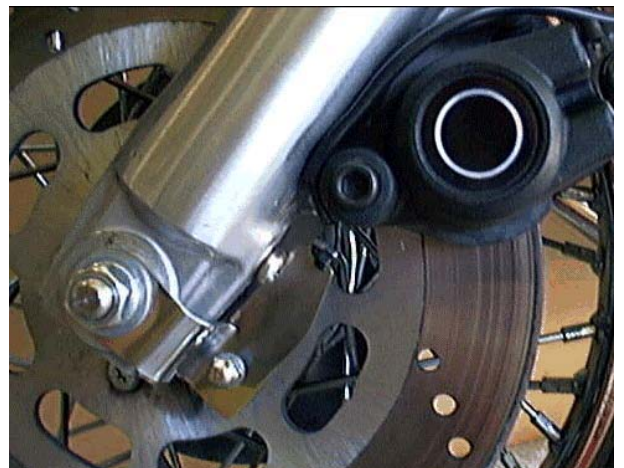

The **Speed Sensor (7)** is on the left fork leg under the brake caliper and mounts on the axle. The magnet fits into the head of one of the bolts that mount the brake disc to the wheel. The photo at right center shows the sensor mounted on the motorcycle.

The **Switch (8)** is mounted to the left hand (clutch) lever handlebar clamp. The bracket mounts between the bottom faces of the clamp and the lever bracket. The clamp must have about 1~1.5mm (0.040"~0.060") filed from the bottom face to allow for the thickness of the switch bracket. The photo at right bottom shows the switch mounted on the motorcycle.



The **Wiring Loom (9)** uses the same type of plugs that are already used on the motorcycle. Brake sensing is taken off the brake light switches by unplugging the rear brake light switch. Matching connectors on the cruise control loom are plugged in to the switch and the bikes loom. Power is taken from the brake system using the same brake connectors. Earth (ground) is sourced on an earth bolt on the motorcycle.

The **Electronic Clutch Switch (ECS)** is now standard on this kit and is connected to the bikes ignition system. If the rider inadvertently disengages the clutch it will cancel the cruise control. It mounts under the speedometer housing on top of the fuel tank.

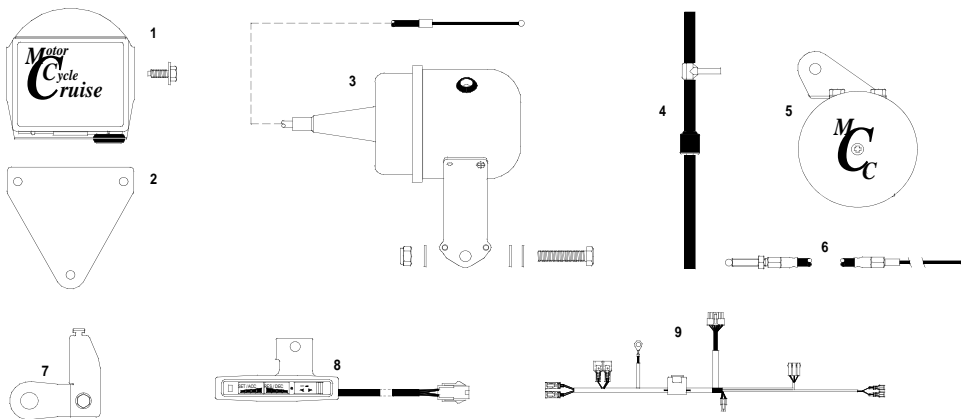

Available for delivery worldwide: [contact us for price details](#)

O.W.L. Vehicle Electronic Systems Ltd
 O.W.L. House PO Box 1330
 TAMWORTH B77 1AG
 UK
 tel 01827 60577 fax 01827 60579
www.motorcyclecruise.co.uk



2003/346