

Electronic Cruise Control for Can-AM Spyder SM5 & SE5



The following provides a brief description of the power consumption and component locations of the MotorCycle electronic cruise control.

Installed weight of the cruise control is approximately 2.3kg.

Current draw while the cruise is switched on, but not engaged, is approximately 0.250 amp (3 watts). Current draw while the cruise is engaged is nominally 0.50~0.80 amp (6~10 Watts).

By comparison, a head light bulb typically draws about 4 amps (55 Watts), and a tail light bulb (running light) draws about 0.4 amp (5 Watts).

Refer to the line drawing on the back of this sheet to identify the component numbers in the text.

The **Actuator (2)** is bolted to the frame on the left side of the bike, to the left of the engine and slightly in front of the engine. A **vacuum hose assembly (3)** is provided to connect the actuator to the engine.



The **Speed sensor (6)** is mounted on the right side of the swing arm, on one of the inner fender mounting bolts. Nickel plated magnets are placed in the heads of the bolts that mount the ABS tone wheel.



The **Computer (1)** mounts behind the head light on the frame, below the instrument cluster.



The **Cable Interface Unit (4)** is located above the front cylinder head on the engine. A new **cable (5)** connects it to the throttle bodies.



On the SM5 (manual shift model) the **Control Switch (7M)** is mounted on the clutch lever mount, below the bike's switch gear.



The **Wiring Loom (9)** has the same type of plugs or terminals that are already used on the motorcycle. Power for the cruise control and brake sensing is taken off the brake light switches by unplugging the rear brake light switch. Matching connectors on the cruise control loom are plugged in to the switch and the bike's loom.

Tach (engine speed) sensing is detected from the bike's ignition coils. This is used to disengage the cruise if the clutch is operated. The bike's clutch switch is also connected to the cruise control to disengage the Cruise control (Manual shift model only). The cruise control is grounded on the negative battery terminal.

On the SE5 (electric shift model) the **Control Switch (7E)** is mounted on the clamp For the paddle shift switch assembly.



Approximately 1.5mm must be filed from the inside face of the clamp bracket for the shift switch to allow for the thickness of the cruise control switch bracket. This clamp bracket is NOT part of the shift switch, but a separate clamp to hold the switch mechanism to the handlebar.

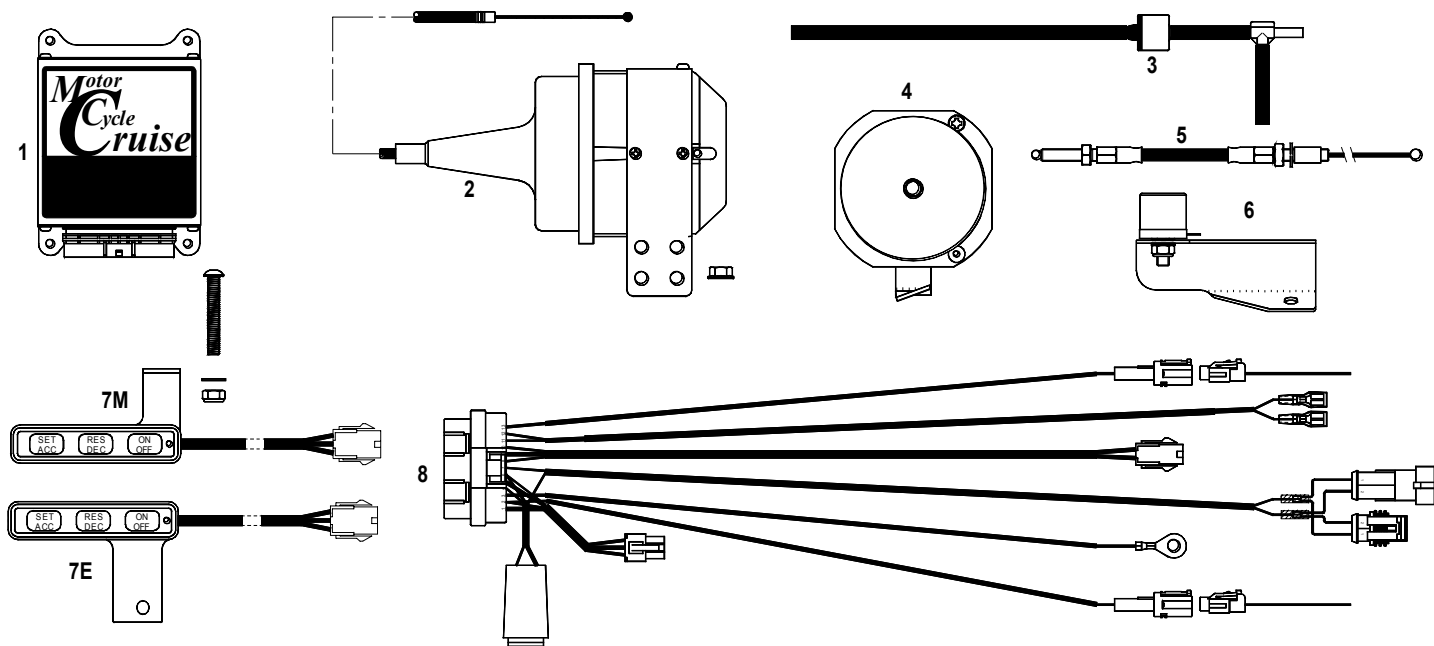

Available for delivery worldwide:
You can contact us via our web enquiry form
http://www.motorcyclecruise.co.uk/contact_us.html

O.W.L. Vehicle Electronic Systems Ltd
 O.W.L. House PO Box 1330
 TAMWORTH B77 1AG
 UK
 tel 01827 60577 fax 01827 60579
www.motorcyclecruise.co.uk



2003/346